



TEST REPORT	
Report Number	WUXH25073101138E
Date of Test	May 8, 2025 - May 15, 2025
Date of issue	May 16, 2025
Name of Testing Laboratory preparing the Report	Shenzhen Wuxiang Testing (Group) Co., Ltd Building B, Xinbaosheng, No.233, Xixiang Street, Bao'an District, Shenzhen, China
Applicant's name	Wuxi Xinje Electric Co., Ltd.
Address	No.816, Jianzhu West Road, Binhu District, Wuxi City, Jiangsu Province, China
Test specification:	
Standard	EN/IEC 61000-6-4:2019 EN/IEC 61000-6-2:2019 EN IEC 61800-3:2023 EN IEC 61000-3-12:2011/A1:2024
Test procedure	/
Non-standard test method	/
Test Report Form No	CE/EMC_1M
Test Report Form(s) Originator	LCIE
Master TRF	Dated 2020-01
<p>This device described above has been tested by WUXH, and the test results show that the equipment under test (EUT) is in compliance with the 2014/30/EU Directive requirements. And it is applicable only to the tested sample identified in the report.</p> <p>This report shall not be reproduced except in full, without the written approval of WUXH, this document may be altered or revised by WUXH, personal only, and shall be noted in the revision of the document.</p>	
Test item description	Servo Driver
Trade Mark	
Manufacturer	Wuxi Xinje Electric Co., Ltd. No.816, Jianzhu West Road, Binhu District, Wuxi City, Jiangsu Province, China
Model/Type reference	For detailed information, please refer to the model list in Chapter 2.1
Ratings	AC 380~440 V, 50/60Hz

****Modified History****

Revision	Description	Issued Data	Remark
Revision 1.0	Initial Test Report Release	2025/5/16	Candy Zheng



WUXIANG

Responsible Testing Laboratory (as applicable), testing procedure and testing location(s):		
<input checked="" type="checkbox"/>	Testing Laboratory:	Shenzhen Wuxiang Testing (Group) Co., Ltd.
Testing location/ address.....:		Building B, Xinbaosheng, No.233, Xixiang Street, Bao'an District, Shenzhen, China
Tested by (name + signature).....:		Test Engineer Candy Zheng 
Approved by (name + signature).....:		Manager Tony Bi 



1. Test Summary

Emission			
Requirement - Test	Test Method		Result
Conducted Emission	EN IEC 61000-6-4:2019 EN IEC 61800-3:2023		PASS
Radiated Emission	EN IEC 61000-6-4:2019 EN IEC 61800-3:2023		PASS
Immunity			
Requirement - Test	Test Method	Performance criteria	Result
Electrostatic discharges	EN 61000-4-2:2009	B	PASS
Radio-frequency electromagnetic field	EN IEC 61000-4-3:2020	A	PASS
Fast transients	EN 61000-4-4:2012	B	PASS
Surges	EN 61000-4-5:2014 + A1:2017	B	PASS
Radio-frequency common mode	EN IEC 61000-4-6:2023	A	PASS
Power frequency magnetic field	EN 61000-4-8:2010	A	N/A
Voltage Dips and Voltage interruptions	EN IEC 61000-4-11:2020	B & B & C & C	PASS

Requirement - Test	Test Method	Limit	Result
Harmonic current emissions	EN IEC 61000-3-2:2019 + A1:2021 + A2:2024	Class A	PASS
Voltage changes, voltage fluctuations and flicker	EN IEC 61800-3:2023	Clause 5	PASS

Remark: N/A is abbreviation for Not Applicable.



2. GENERAL INFORMATION

2.1 Description of Device (EUT)

EUT:	Servo Driver
Model Number:	DS5C2-47P5-PTA
Model Difference:	DS5C2-47P5-PTA is the test model, while other models are derivative models. These models are the same on the circuit, only with different model names. Therefore, the test data of DS5C2-47P5-PTA can represent the remaining models.
Power Supply:	AC 380~440 V, 50/60Hz
Testing Voltage:	AC 380 V/50 Hz
Highest Frequency Generated:	Below 108 MHz

Model List

Model Name:
DS5C2-47P5-PTA DS5C2-47P5-PTA, DS5C5-45P5-PTA, DS5C5-47P5-PTA, DS5C2-45P5-PTA, DS5P-45P5-PTA, DS5P-47P5-PTA, DS5C1-45P5-PTA-FH, DS5C1-47P5-PTA-FH, DS5P-47P5-PTA-FH, DS5C2-45P5-PTA-FS, DS5C2-47P5-PTA-FS, DS5C2-415P0-PTA, DS5C2-432P0-PTA, DS5K2-45P5-PTA, DS5K2-47P5-PTA, DM6C-415P0-M, DS5C1-45P5-PTA, DS5C1-47P5-PTA, DS5C1-411P0-PTA, DS5C1-415P0-PTA, DS5C1-422P0-PTA, DS5C1-432P0-PTA, DS5K1-411P0-PTA, DS5K1-415P0-PTA, DS5F-45P5-PTA-H, DS5F-47P5-PTA-H, DS5C2-422P0-PTA, DS5C2-432P0-PTA, DS5K1-422P0-PTA-ZW, DS5K1-432P0-PTA-ZW
NOTE:DS5C2-47P5-PTA is the test model, while other models are derivative models. These models are the same on the circuit, only with different model names. Therefore, the test data of DS5C2-47P5-PTA can represent the remaining models.



WUXIANG

2.2 Other Accessory Device List and Details

Description	Manufacturer	Model	Note
/	/	/	/
/	/	/	/

2.3 Block diagram of EUT configuration

Mode 1

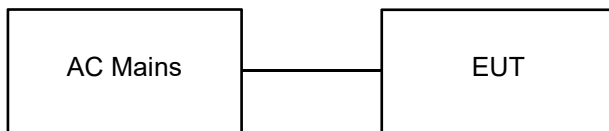
**2.4 Test Mode**

Pretest mode	Mode 1: Working mode		
Worst-case Test mode	Conducted Emission		Mode 1
	Radiated Emission	Below 1 GHz	Mode 1
		Above 1 GHz	N/A
	Harmonic current emissions		Mode 1
	Voltage changes, voltage fluctuations and flicker		Mode 1
	Electrostatic discharges		Mode 1
	Radio-frequency electromagnetic fields		Mode 1
	Fast transients		Mode 1
	Surges		Mode 1
	Injected currents		Mode 1
	Power frequency magnetic field		N/A
	Voltage dips and short interruptions		Mode 1

* Only the worst-case data is represented in the report.

2.5 Test Site Environment

Test Item	Required (IEC 60068-1)		Actual
Conducted Emission	Temperature (°C)	15-35	23.6
	Humidity (%RH)	25-75	53.8
	Barometric pressure (mbar)	860-1060	1014
Radiated Emission	Temperature (°C)	15-35	24.0
	Humidity (%RH)	25-75	54
	Barometric pressure (mbar)	860-1060	1004
Harmonic current emissions	Temperature (°C)	--	23.8
	Humidity (%RH)	--	54.5
	Barometric pressure (mbar)	--	1014
Voltage Fluctuations & Flicker	Temperature (°C)	--	23.8
	Humidity (%RH)	--	54.5
	Barometric pressure (mbar)	--	1014
Electrostatic discharges	Temperature (°C)	15-35	24.0
	Humidity (%RH)	30-60	52.0
	Barometric pressure (mbar)	860-1060	1014
Fast transients	Temperature (°C)	15-35	24.1
	Humidity (%RH)	25-75	53.6
	Barometric pressure (mbar)	860-1060	1014
Surges	Temperature (°C)	15-35	24.1
	Humidity (%RH)	25-75	53.6
	Barometric pressure (mbar)	860-1060	1014
Injected currents	Temperature (°C)	15-35	24.1
	Humidity (%RH)	25-75	53.6
	Barometric pressure (mbar)	860-1060	1014
Voltage dips and short interruptions	Temperature (°C)	15-35	24.1
	Humidity (%RH)	25-75	53.6
	Barometric pressure (mbar)	860-1060	1014

2.6 Test Instrument Used

Conducted emissions Test					
Equipment	Manufacturer	Model#	Serial#	Last Cal.	Next Cal.
Receiver	R&S	ESR	102075	Sept. 21, 2024	Sept. 20, 2025
LISN	R&S	ENV216	101375	Sept. 21, 2024	Sept. 20, 2025
ISN	HPX	ISN T800	S1509001	Sept. 21, 2024	Sept. 20, 2025

Radiated emissions Test (966 chamber)					
Equipment	Manufacturer	Model#	Serial#	Last Cal.	Next Cal.
966 chamber	ChengYu	966 Room	966	Sept. 21, 2024	Sept. 20, 2025
Receiver	R&S	ESRP	101154	Sept. 21, 2024	Sept. 20, 2025
Amplifier	Schwarzbeck	BBV9718	9718-309	Sept. 21, 2024	Sept. 20, 2025
Amplifier	Schwarzbeck	BBV9744	9744-0037	Sept. 21, 2024	Sept. 20, 2025
TRILOG Broadband Antenna	schwarzbeck	VULB 9163	VULB9163-942	Sept. 21, 2024	Sept. 20, 2025
Horn Antenna	SCHWARZBECK	BBHA9120D	1201	Sept. 21, 2024	Sept. 20, 2025

Harmonic current emissions/Flicker					
Equipment	Manufacturer	Model#	Serial#	Last Cal.	Next Cal.
Harmonic & Flicker Tester	LAPLAEC	AC2000A	439263	Sept. 21, 2024	Sept. 20, 2025
AC Power Supply	LAPLAEC	PCR4000 M	631589	Sept. 21, 2024	Sept. 20, 2025

Electrostatic discharge Test					
Equipment	Manufacturer	Model#	Serial#	Last Cal.	Next Cal.
ESD Tester	3C TEST	EDS 30V	ES0121614	Sept. 21, 2024	Sept. 20, 2025
ESD Tester	KIKISUI	KES4201A	UH002321	Sept. 21, 2024	Sept. 20, 2025

Continuous RF electromagnetic field disturbances Test					
Equipment	Manufacturer	Model#	Serial#	Last Cal.	Next Cal.
Signal Generator	HP	8648A	3625U00573	Sept. 21, 2024	Sept. 20, 2025
Amplifier	A&R	500A100	17034	Sept. 21, 2024	Sept. 20, 2025
Amplifier	A&R	100W/1000M1	17028	Sept. 21, 2024	Sept. 20, 2025
Audio Analyzer (20Hz~1GHz)	Panasonic	2023B	202301/428	Sept. 21, 2024	Sept. 20, 2025
Isotropic Field Probe	A&R	FP2000	16755	Sept. 21, 2024	Sept. 20, 2025
Antenna	EMCO	3108	9507-2534	Sept. 21, 2024	Sept. 20, 2025
Log-periodic Antenna	A&R	AT1080	16812	Sept. 21, 2024	Sept. 20, 2025

EFT and Surge and Voltage dips and interruptions Test					
Equipment	Manufacturer	Model#	Serial#	Last Cal.	Next Cal.
Compact Generator	TRANSIENT	TRA2000	646	Sept. 21, 2024	Sept. 20, 2025
Coupling Clamp	PARTNER	CN-EFT1000	CN-EFT100 0-1624	Sept. 21, 2024	Sept. 20, 2025

Continuous induced RF disturbances Test					
Equipment	Manufacturer	Model#	Serial#	Last Cal.	Next Cal.
C/S Test System	SCHLODER	CDG-6000-75	126B1405/20 16	Sept. 21, 2024	Sept. 20, 2025
Attenuator	SCHLODER	6DB DC-1G	HA1630	Sept. 21, 2024	Sept. 20, 2025
CDN	SCHLODER	CDN M2/M3	A2210389/20 16	Sept. 21, 2024	Sept. 20, 2025
Injection Clamp	SCHLOBER	EMCL-20	132A1272/20 16	Sept. 21, 2024	Sept. 20, 2025

2.7 Testing software

Project	Software name	Edition
Conducted Emission	EZ-EMC	EMC-CON 3A1.1+
Radiated Emission	EZ-EMC	FA-03A2 RE+
Conducted Susceptibility	IEC/EN 61000-4-6	1.4.1
Harmonic current emissions	Harmonic	121

2.8 Measurement uncertainty

Where relevant, the following measurement uncertainty levels have been estimated for tests performed on the Product as specified in CISPR 16-4-2. This uncertainty represents an expanded uncertainty expressed at approximately the 95% confidence level using a coverage factor of k=2.

Test item	Value (dB)
Conducted Emission (150kHz-30MHz)	2.60
Radiated Emission(30MHz~1GHz)	4.60
Radiated Emission(1GHz~6GHz)	4.30

Decision Rule

- Uncertainty is not included
 Uncertainty is included

3. Conducted Emission

3.1 .Limit

A.C. Mains Conducted Interference Limit

Frequency (MHz)	Class A (dBuV)		Class B (dBuV)	
	Quasi-peak	Average	Quasi-peak	Average
0.15 - 0.5	79	66	66 - 56	56 - 46
0.50 - 5.0	73	60	56	46
5.0 - 30.0	73	60	60	50

Note:

- (1) The lower limit shall apply at the transition frequencies.
- (2) The limit decreases in line with the logarithm of the frequency in the range 0.15 to 0.50 MHz.
- (3) All emanations from a class A/B digital device or system, including any network of conductors and apparatus connected thereto, shall not exceed the level of field strengths specified above.

Telecommunication Port Asymmetric mode Conducted Interference Limit

Requirement (MHz)	Class A Equipment				Class B Equipment			
	Voltage Limit (dB μ V)		Current Limit (dB μ A)		Voltage Limit (dB μ V)		Current Limit (dB μ A)	
	QP	Avg.	QP	Avg.	QP	Avg.	QP	Avg.
0.15 to 0.50	97 to 87	84 to 74	53 to 43	40 to 30	84 to 74	74 to 64	40 to 30	30 to 20
0.50 to 30	87	74	43	30	74	64	30	20

3.2 Test setup

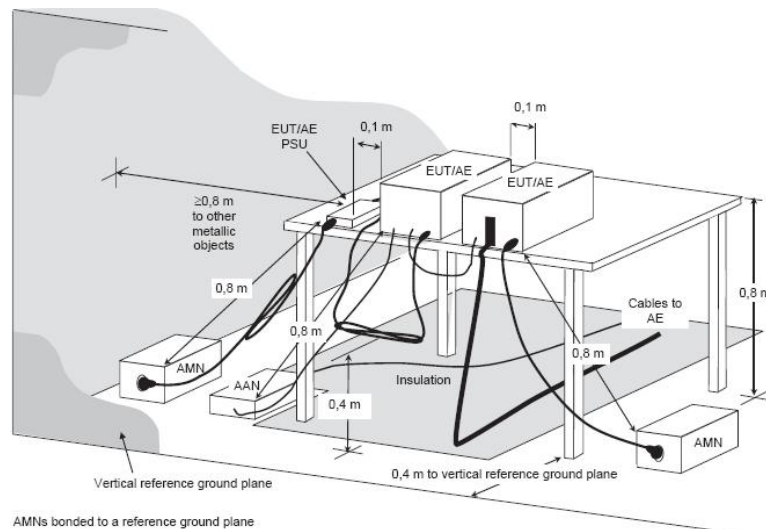

3.3 Test Procedure

- a. The EUT was placed 0.4 meters from the conducting wall of the shielded room with EUT being connected to the power mains through a line impedance stabilization network (LISN). Other support units were connected to the power mains through another LISN. The two LISNs provide 50 Ohm/ 50uH of coupling impedance for the measuring instrument.
- b. Both lines of the power mains connected to the EUT were checked for maximum conducted interference.
- c. The test results of conducted emissions at mains ports are recorded of six worst margins for quasi-peak(mandatory) [and average (if necessary)] values against the limits at frequencies of interest unless the margin is 20 dB or greater.
Note: The resolution bandwidth and video bandwidth of test receiver is 9kHz for quasi-peak detection (QP) and average detection (AV) at frequency 0.15MHz-30MHz.

3.4 Test Result

PASS

Please refer to the following page.Only the Worst-case test mode is shown in the report.



WUXIANG

Phase: Live

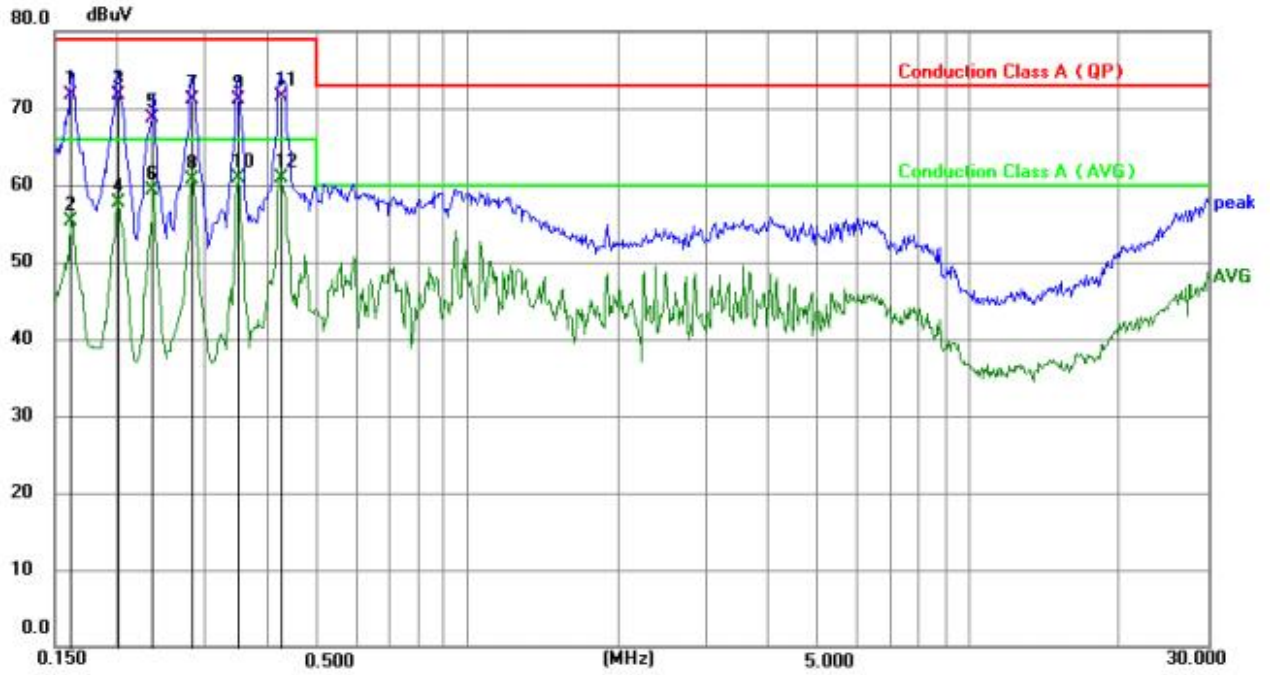

No.	Frequency (MHz)	Reading (dBuV)	Factor (dB)	Level (dBuV)	Limit (dBuV)	Margin (dB)	Detector	P/F	Remark
1	0.1621	61.73	9.89	71.62	79.00	-7.38	QP	P	
2	0.1621	45.36	9.89	55.25	66.00	-10.75	AVG	P	
3	0.2006	61.85	9.91	71.76	79.00	-7.24	QP	P	
4	0.2006	47.76	9.91	57.67	66.00	-8.33	AVG	P	
5	0.2353	58.74	9.92	68.66	79.00	-10.34	QP	P	
6	0.2353	49.35	9.92	59.27	66.00	-6.73	AVG	P	
7	0.2805	61.17	9.94	71.11	79.00	-7.89	QP	P	
8	0.2805	50.71	9.94	60.65	66.00	-5.35	AVG	P	
9	0.3480	61.15	9.96	71.11	79.00	-7.89	QP	P	
10	0.3480	50.90	9.96	60.86	66.00	-5.14	AVG	P	
11	0.4243	61.58	9.99	71.57	79.00	-7.43	QP	P	
12 *	0.4243	51.01	9.99	61.00	66.00	-5.00	AVG	P	

Phase: Neutral

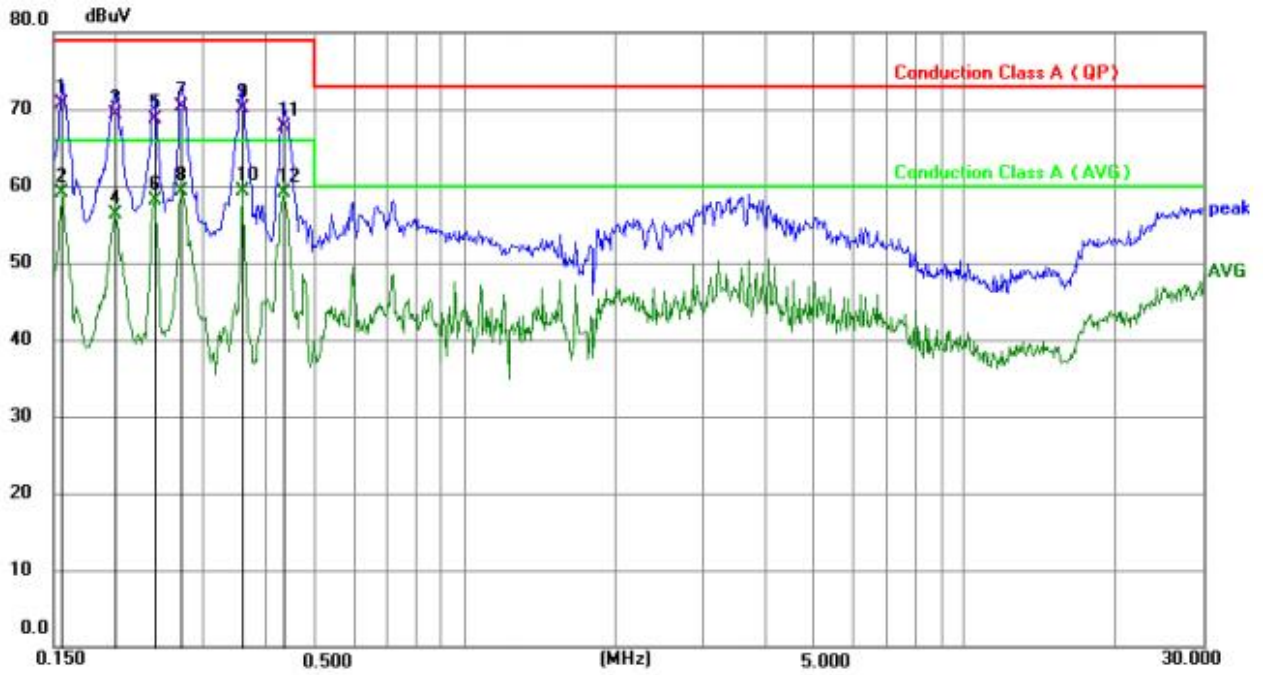

No.	Frequency (MHz)	Reading (dBuV)	Factor (dB)	Level (dBuV)	Limit (dBuV)	Margin (dB)	Detector	P/F	Remark
1	0.1554	60.90	9.89	70.79	79.00	-8.21	QP	P	
2	0.1554	49.15	9.89	59.04	66.00	-6.96	AVG	P	
3	0.1995	59.33	9.91	69.24	79.00	-9.76	QP	P	
4	0.1995	46.32	9.91	56.23	66.00	-9.77	AVG	P	
5	0.2391	58.70	9.93	68.63	79.00	-10.37	QP	P	
6	0.2391	48.23	9.93	58.16	66.00	-7.84	AVG	P	
7	0.2714	60.35	9.94	70.29	79.00	-8.71	QP	P	
8 *	0.2714	49.37	9.94	59.31	66.00	-6.69	AVG	P	
9	0.3570	60.12	9.97	70.09	79.00	-8.91	QP	P	
10	0.3570	49.24	9.97	59.21	66.00	-6.79	AVG	P	
11	0.4328	57.71	10.00	67.71	79.00	-11.29	QP	P	
12	0.4328	49.11	10.00	59.11	66.00	-6.89	AVG	P	

4. Radiated emission test 4.1 Limit

Frequency (MHz)	dBuV/m (Distance 3m)
30 ~ 230	50
230 ~ 1000	57

4.2 Block diagram of test setup

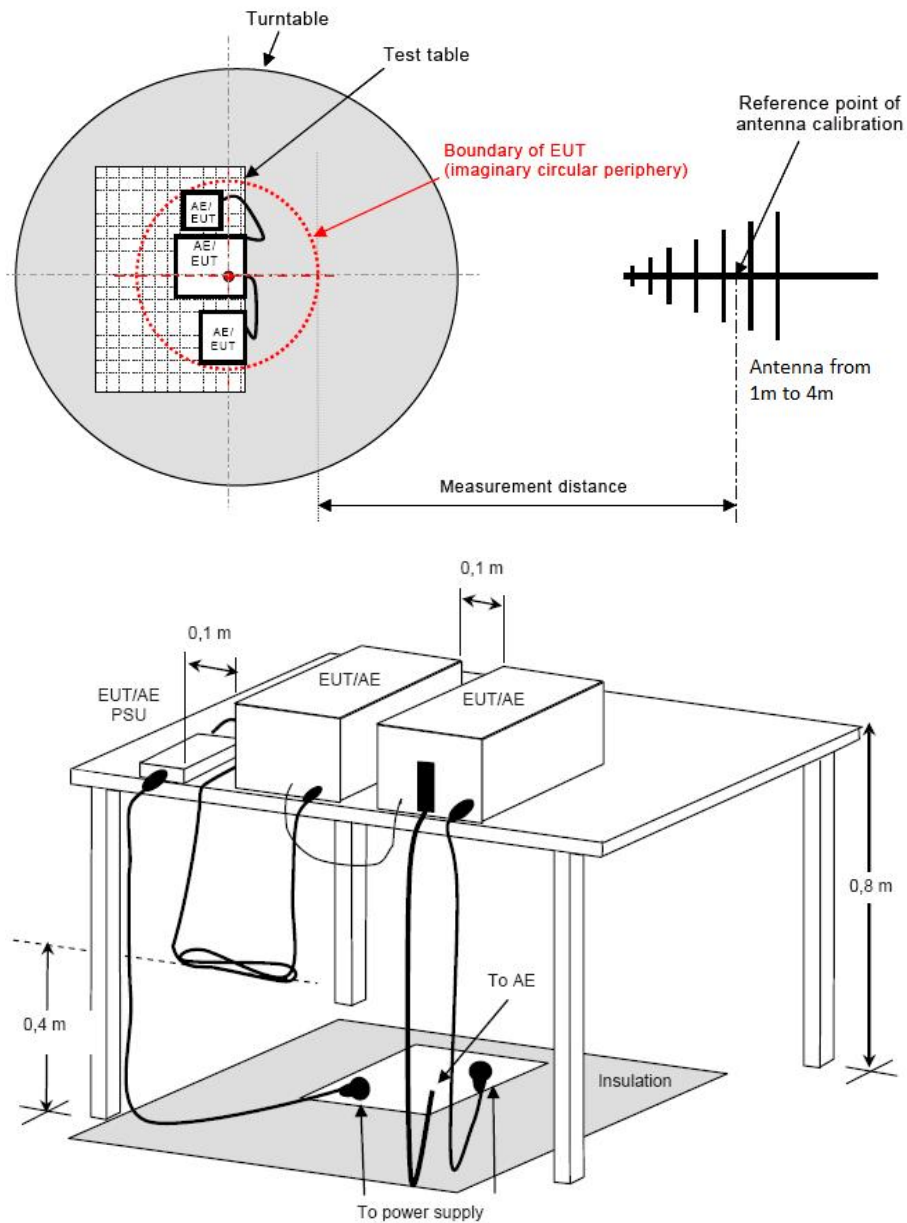

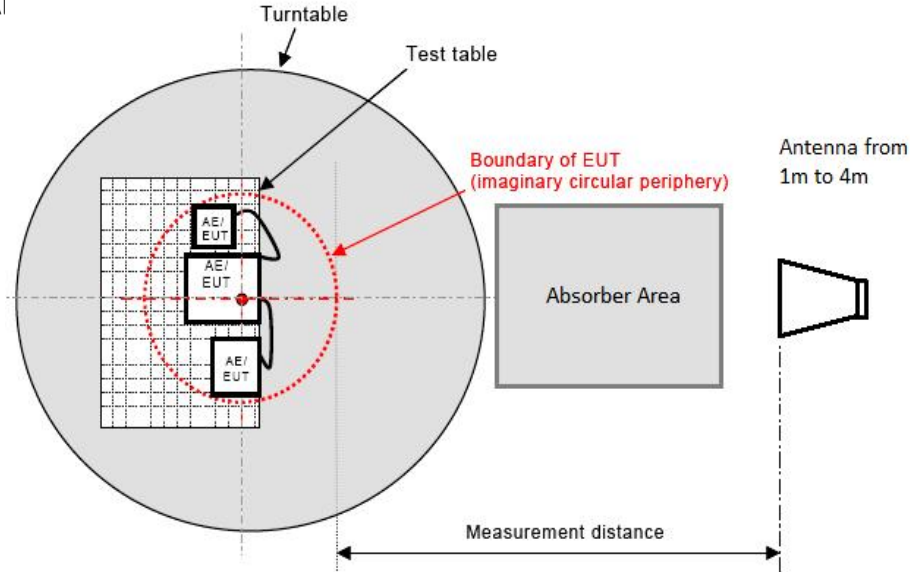

4.3 Test Procedure

The EUT and its simulators are placed on a turned table that is 0.8 meter above the ground. The turned table can rotate 360 degrees to determine the position of the maximum emission level. The EUT is set 3 meters away from the receiving antenna that is mounted on the antenna tower. The antenna can move up and down between 1 meter and 4 meters to find out the maximum emission level. Broadband antenna (calibrated biconical and log periodical antenna) is used as receiving antenna. Both horizontal and vertical polarization of the antenna is set on test. In order to find the maximum emission levels, the interface cable must be manipulated according to EN55015 on radiated emission test.

The bandwidth setting on the field strength meter (R&S Test Receiver ESCI) is set at 120kHz.

The frequency range from 30MHz to 1000MHz is checked.

4.4 Test Result

PASS

Please refer to the following page. Only the Worst-case test mode is shown in the report.

Polarization: Horizontal

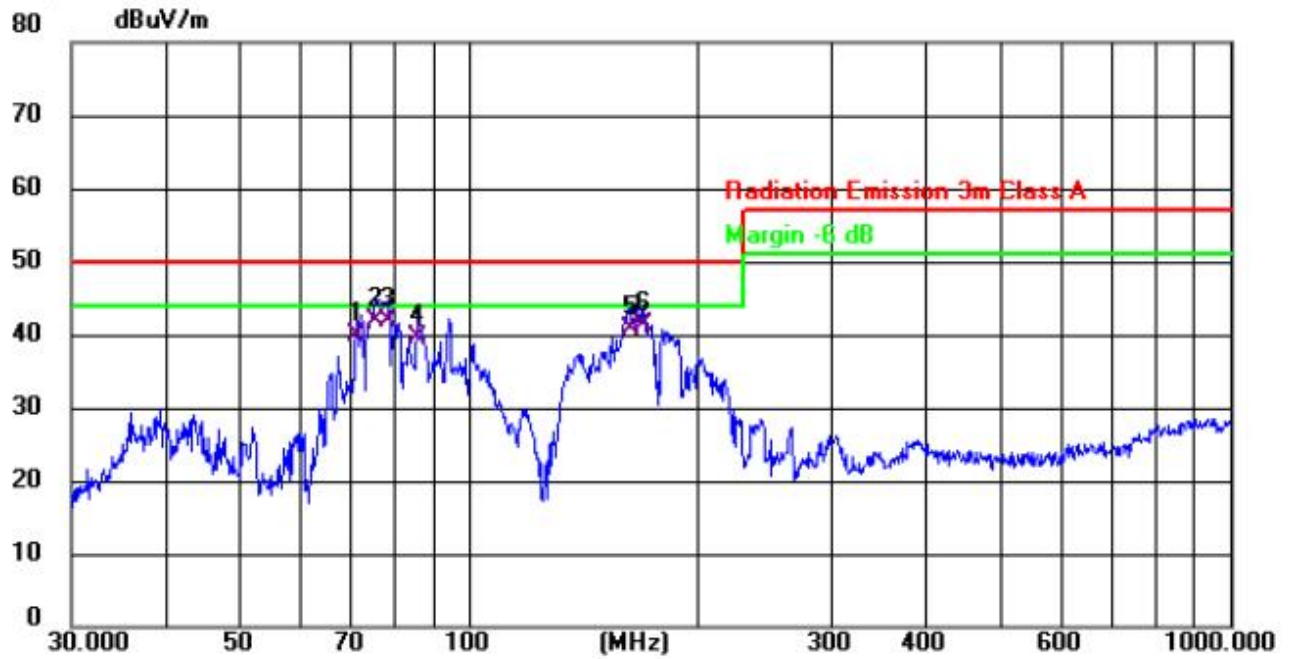

No.	Frequency (MHz)	Reading (dBuV)	Factor (dB/m)	Level (dBuV/m)	Limit (dBuV/m)	Margin (dB)	Detector	Height (cm)	Azimuth (deg.)	P/F	Remark
1	71.0802	52.52	-12.65	39.87	50.00	-10.13	QP			P	
2 *	75.4462	55.08	-13.30	41.78	50.00	-8.22	QP			P	
3	78.1388	55.47	-13.70	41.77	50.00	-8.23	QP			P	
4	85.2980	52.66	-13.06	39.60	50.00	-10.40	QP			P	
5	162.6105	53.96	-13.12	40.84	50.00	-9.16	QP			P	
6	169.0053	53.92	-12.72	41.20	50.00	-8.80	QP			P	

Polarization: Vertical

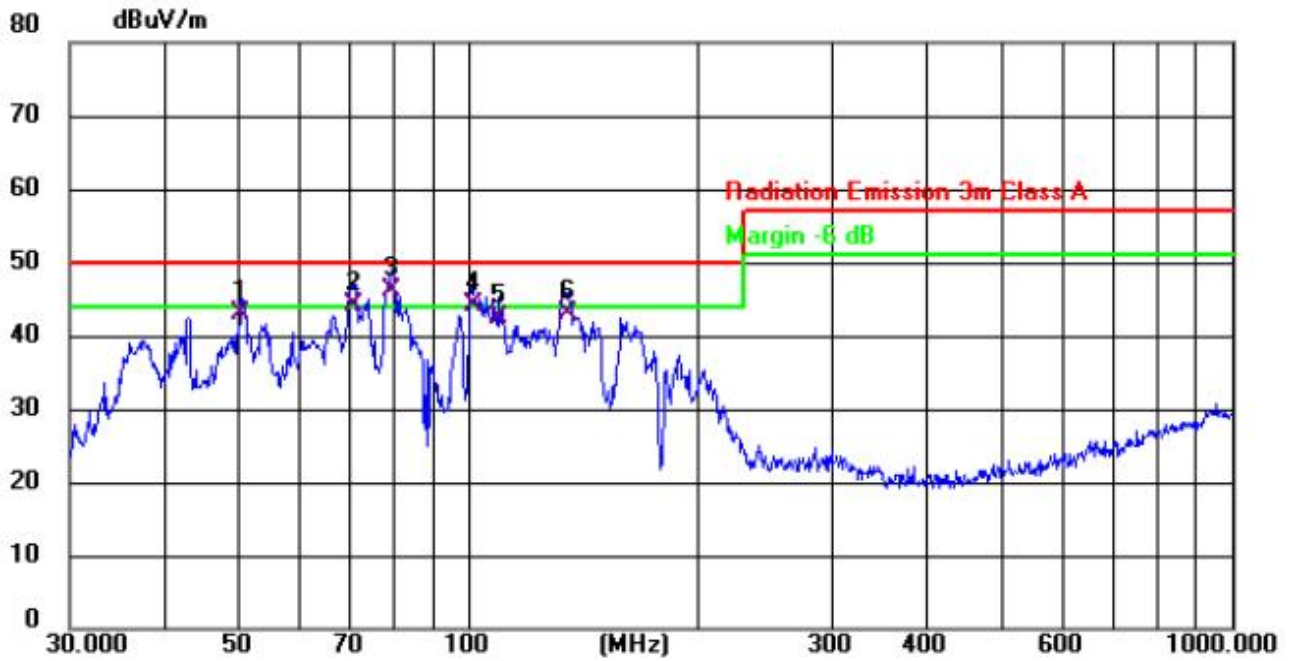

No.	Frequency (MHz)	Reading (dBuV)	Factor (dB/m)	Level (dBuV/m)	Limit (dBuV/m)	Margin (dB)	Detector	Height (cm)	Azimuth (deg.)	P/F	Remark
1	50.4090	51.36	-8.47	42.89	50.00	-7.11	QP			P	
2 !	70.8315	56.62	-12.61	44.01	50.00	-5.99	QP			P	
3 *	79.2425	59.87	-13.86	46.01	50.00	-3.99	QP			P	
4 !	101.2883	54.84	-10.67	44.17	50.00	-5.83	QP			P	
5	109.7960	53.88	-11.59	42.29	50.00	-7.71	QP			P	
6	134.5591	56.25	-13.28	42.97	50.00	-7.03	QP			P	

5. Harmonic current emissions

5.1 Limit

Current emission limits for equipment other than balanced three-phase equipment

Minimum R_{sce}	Admissible individual harmonic current I_h/I_{ref} ^a %						Admissible harmonic parameters %	
	I_3	I_5	I_7	I_9	I_{11}	I_{13}	THC/I_{ref}	$PWHC/I_{ref}$
33	21,6	10,7	7,2	3,8	3,1	2	23	23
66	24	13	8	5	4	3	26	26
120	27	15	10	6	5	4	30	30
250	35	20	13	9	8	6	40	40
≥350	41	24	15	12	10	8	47	47

The relative values of even harmonics up to order 12 shall not exceed $16/h$ %. Even harmonics above order 12 are taken into account in THC and $PWHC$ in the same way as odd order harmonics.

Linear interpolation between successive R_{sce} values is permitted.

^a I_{ref} = reference current; I_h = harmonic current component.

5.2 Test Procedure

The EUT was placed on the top of a wooden table 0.8 meters above the ground and the EUT is supplied in series with power analyzer from a power source having the same normal voltage and frequency as the rated supply voltage and the equipment under test. And the rated voltage at the supply voltage of EUT of 0.94 times and 1.06 times shall be performed.

A definition of the normal load or of the conditions for adequate heat discharge can usually be found in the EN publication corresponding to the equipment under test.

Equipment may have several separately controlled circuits. Each circuit is considered as a single piece of equipment if it can be operated independently and separately from the other circuits.

5.3 Test Results

PASS

6. VOLTAGE FLUCTUATIONS & FLICKER TEST

6.1 Limit

Test Item	Limit
Pst (Short-term flicker indicator.)	1.0
Plt (Long-term flicker indicator.)	0.65
Td(t)(ms) (Maximum time that d(t) exceeds 3.3%)	500
dmax(%) (Maximum relative voltage change.)	4
dc(%) (Relative steady-state voltage change)	3.3

6.2 Test Procedure

The EUT is supplied in series with power analyzer from a power source having the same normal voltage and frequency as the rated supply voltage and the equipment under test. And the rated voltage at the supply voltage of EUT of 0.94 times and 1.06 times shall be performed.

The EUT was placed on the top of a wooden table 0.8 meters above the ground and operated to produce the most unfavorable sequence of voltage changes under normal operating conditions.

During the flick measurement, the measure time shall include that part of whole operation cycle in which the EUT produce the most unfavorable sequence of voltage changes. The observation period for short-term flicker indicator is 10 minutes and the observation period for long-term flicker indicator is 2 hours.

6.3 Test Results

PASS

7. Electrostatic Discharge immunity Test

7.1 Test Specification

Test Port	:	Enclosure port
Discharge Impedance	:	330 ohm / 150 pF
Discharge Mode	:	Single Discharge
Discharge Period	:	one second between each discharge

7.2 Test Standard

EN IEC 61000-6-1:2019
(EN 61000-4-2:2009)

Level	Test Voltage Contact Discharge (KV)	Test Voltage Air Discharge (KV)
1.	±2	±2
2.	±4	±4
3.	±6	±8
4.	±8	±15
X	Special	Special

Performance criterion: **B**

7.3 Test setup

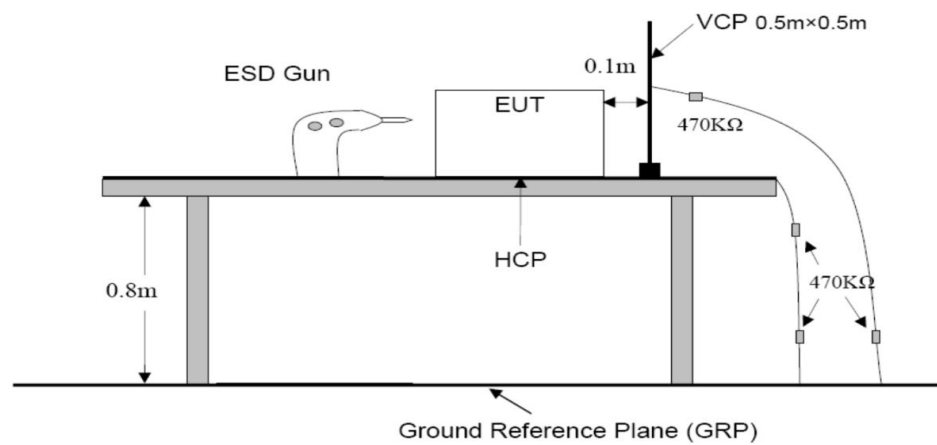

7.4 Test Procedure

Air Discharge:

This test is done on a non-conductive surface. The round discharge tip of the discharge electrode shall be approached as fast as possible to touch the E.U.T.. After each discharge, the discharge electrode shall be removed from the E.U.T.. The generator is then re-triggered for a new single discharge and repeated (10 of each polarity) for each pre-selected test point. This procedure shall be repeated until all the air discharge completed.

Contact Discharge:

All the procedure shall be same as Section Air Discharge except that the tip of the discharge electrode shall touch the E.U.T..

Indirect discharge for horizontal coupling plane:

At least 10 single discharges(in the most sensitive polarity) shall be applied at the front edge of each HCP opposite the center point of each unit(if applicable) of the E.U.T. and 0.1m from the front of the E.U.T.. The long axis of the discharge electrode shall be in the plane of the HCP and perpendicular to its front edge during the discharge.

Indirect discharge for vertical coupling plane:

At least 10 single discharge (in the most sensitive polarity) shall be applied to the center of one vertical edge of the coupling plane. The coupling plane, of dimensions 0.5m X 0.5m, is placed parallel to, and positioned at a distance of 0.1m from the E.U.T.. Discharges shall be applied to the coupling plane, with this plane in sufficient different positions that the four faces of the E.U.T. are completely illuminated.

7.5 Test Results

PASS

ESD Test Data				
Air Discharge: $\pm 8KV$ Contact Discharge: $\pm 4KV$				
Test Points	Air Discharge	Contact Discharge	Performance Criterion	Result
Enclosure	$\pm 2,4,8KV$	N/A	B	PASS
Slit	$\pm 2,4,8KV$	N/A	B	PASS
Metal Part	N/A	$\pm 2,4 KV$	B	PASS
VCP	N/A	$\pm 2,4 KV$	B	PASS
HCP	N/A	$\pm 2,4 KV$	B	PASS
Note: N/A means not applicable				

8. RF FIELD STRENGTH SUSCEPTIBILITY TEST

8.1 Test Specification

Test Port	:	Enclosure port
Step Size	:	1%
Modulation	:	1kHz, 80% AM
Dwell Time	:	1 second
Polarization	:	Horizontal & Vertical

8.2 Test Levels and Performance Criterion

EN IEC 61000-6-1:2019
(EN IEC 61000-4-3:2020)

Characteristics	Test levels	
Frequency range	80 MHz to 1 000 MHz, 1 400 MHz to 2 000 MHz,	2 000 MHz to 2 700 MHz
Test level	3 V/m (unmodulated)	1 V/m (unmodulated)
Modulation	1 kHz, 80 % AM, sine wave	1 kHz, 80 % AM, sine wave

Performance criterion: **A**

8.3 Test setup

For table-top equipment

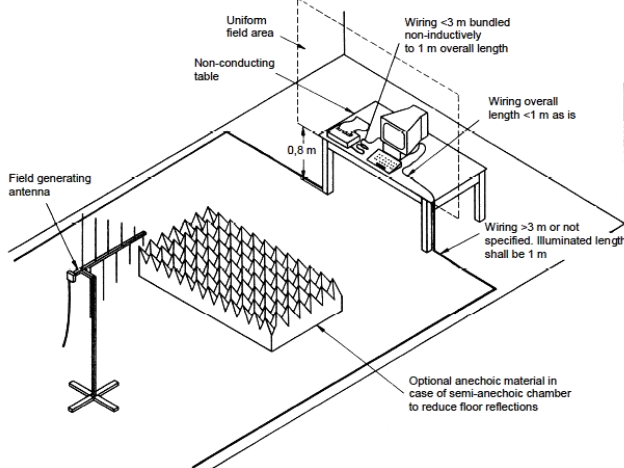

For floor standing equipment

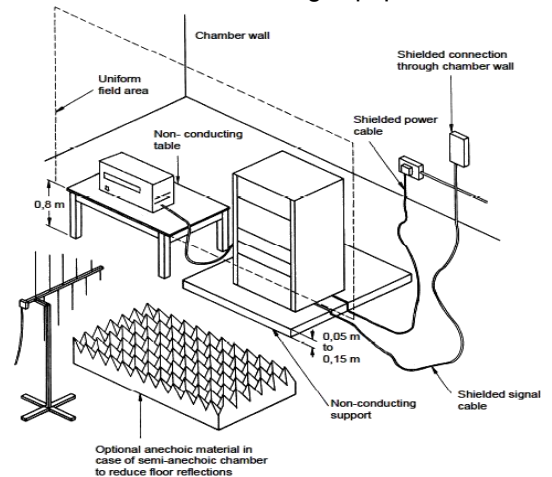

8.4 Test Procedure

The EUT and its simulators are placed on a turn table which is 0.8 meter above ground. EUT is set 3 meter away from the transmitting antenna which is mounted on an antenna tower. Both horizontal and vertical polarization of the antenna are set on test. Each of the four sides of EUT must be faced this transmitting antenna and measured individually.

All the scanning conditions are as follows :

Condition of Test	Remarks
1. Fielded Strength	3 V/m (Severity Level 2)
2. Radiated Signal	Modulated
3. Scanning Frequency	80 – 1000 MHz
4. Dwell time of radiated	0.0015 decade/s
5. Waiting Time	1 Sec.

8.5 Test Results

PASS

Frequency (MHz)	Polarization	Test level (V/m)	Modulation	Exposed location	Result (Performance Criterion)
80-1 000, 1 400-2000	H & V	3	1 kHz, 80% AM, 1 % increment	All sides	A
2 000 - 2 700	H & V	1	1 kHz, 80% AM, 1 % increment	All sides	A



9. Electrical Fast Transient/Burst Immunity Test

9.1 Test Specification

Test Port	:	input a.c. power port
Impulse Frequency	:	5 kHz
Impulse Wave-shape	:	5/50 ns
Burst Duration	:	15 ms
Burst Period	:	300 ms
Test Duration	:	2 minutes per polarity

9.2 Test Levels and Performance Criterion

EN IEC 61000-6-1:2019

(EN 61000-4-4:2012)

Open circuit output test voltage and repetition rate of the impulses				
Level	On power port, PE		On I/O (Input/Output) Signal data and control ports	
	Voltage peak KV	Repetition rate KHz	Voltage peak KV	Repetition rate KHz
1.	0.5	5 or 100	0.25	5 or 100
2.	1.0	5 or 100	0.5	5 or 100
3.	2.0	5 or 100	1.0	5 or 100
4.	4.0	5 or 100	2.0	5 or 100
X	Special	Special	Special	Special

Note 1 Use of 5 KHz repetition rates is traditional; however, 100 KHz is closer to reality. Product committees should determine which frequencies are relevant for specific products or product types.

Note 2 With some products, there may be no clear distinction, between power ports and I/O ports, in which case it is up to product committees to make this determination for test purposes.

Note 3 "X" is an open level. The level has to be specified in the dedicated equipment specification.

Performance criterion: **B**

9.3 Test setup

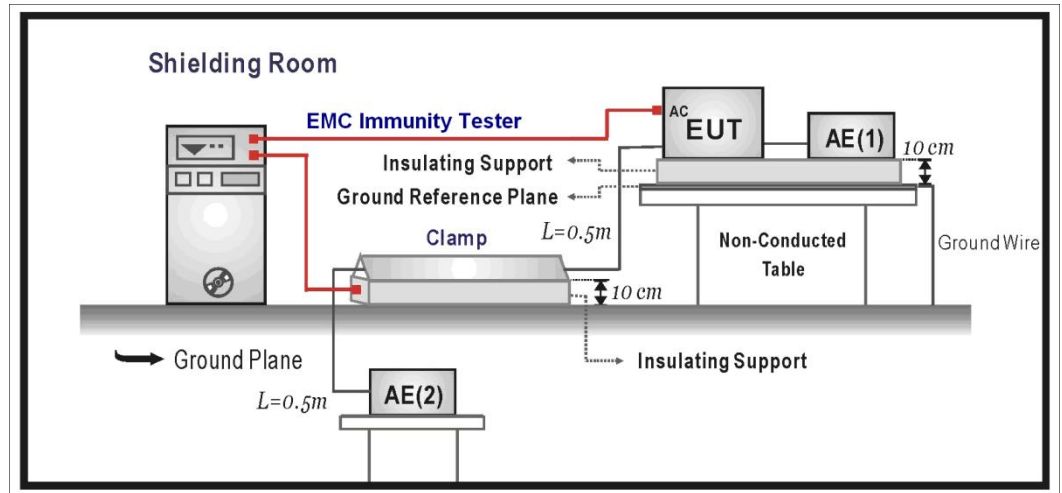

9.4 Test Procedure

The E.U.T. is put on the table which is 0.8 meter high above the ground. This reference ground plane shall project beyond the E.U.T. by at least 0.1m on all sides and the minimum distance between E.U.T. and all other conductive structure, except the ground plane beneath the E.U.T., shall be more than 0.5m.

For AC mains power ports:

The E.U.T. is connected to the power mains by using a coupling device which couples the EFT interference signal to AC power lines. Both polarities of the test voltage should be applied during compliance test and the duration of the test is 2 minus.

For analogue/digital data ports:

The E.U.T. is connected to the power mains by using a coupling device which couples the EFT interference signal to Signal lines. Both polarities of the test voltage should be applied during compliance test and the duration of the test is 2 minus.

For DC network power ports:

Applicable only to ports which, according to the manufacturer's specification, support cable lengths greater than 3 m.

9.5 Test Results

PASS

Test Point	Polarity	Test Level (kV)	Inject Time (Second)	Inject Method	Performance Criterion	Result (Performance Criterion)
L	±	1	60	Direct	<input type="checkbox"/> A <input checked="" type="checkbox"/> B	A
N	±	1	60	Direct	<input type="checkbox"/> A <input checked="" type="checkbox"/> B	A
PE	±	1	60	Direct	<input type="checkbox"/> A <input checked="" type="checkbox"/> B	A
L+N	±	1	60	Direct	<input type="checkbox"/> A <input checked="" type="checkbox"/> B	A
L+PE	±	1	60	Direct	<input type="checkbox"/> A <input checked="" type="checkbox"/> B	A
N+PE	±	1	60	Direct	<input type="checkbox"/> A <input checked="" type="checkbox"/> B	A
L+N+PE	±	1	60	Direct	<input type="checkbox"/> A <input checked="" type="checkbox"/> B	A

10. SURGE Test

10.1 Test Specification

Test Port	:	input a.c. power port
Wave-Shape	:	Open Circuit Voltage - 1.2 / 50 us Short Circuit Current - 8 / 20 us
Pulse Repetition Rate	:	1 pulse / min.
Phase Angle	:	0° / 90° / 180° / 270°
Test Events	:	5 pulses (positive & negative) for each polarity

10.2 Test Levels and Performance Criterion

EN IEC 61000-6-1:2019
(EN 61000-4-5:2014 + A1:2017)

Severity Level	Open-Circuit Test Voltage KV
1	0.5
2	1.0
3	2.0
4	4.0
*	Special

Performance criterion: C

10.3 Test setup

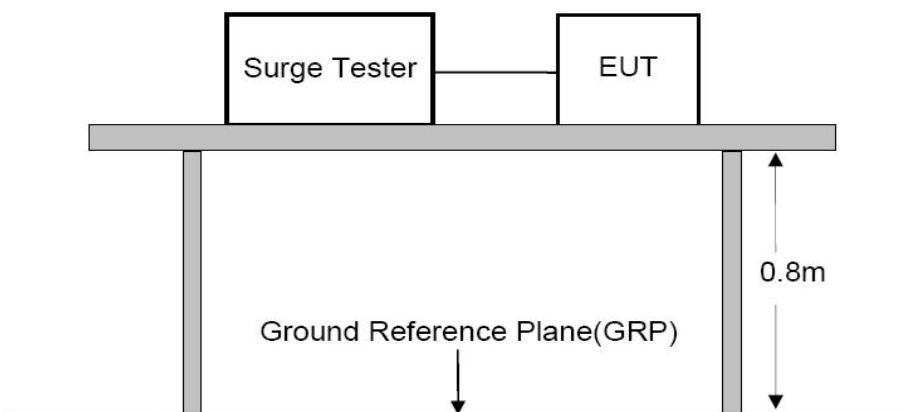

10.4 Test Procedure

- 1) Set up the EUT and test generator as shown on section 10.1.
- 2) For line to line coupling mode, provide a 1KV 1.2/50us voltage surge (at open-circuit condition) and 8/20us current surge to EUT selected points.
- 3) At least 5 positive and 5 negative (polarity) tests with a maximum 1/min repetition rate are conducted during test.
- 4) Different phase angles are done individually.
- 5) Repeat procedure 2) to 4) except the open-circuit test voltage change from 1KV to 2KV for line to earth coupling mode test.
- 6) Record the EUT operating situation during compliance test and decide the EUT immunity criterion for above each test.

10.5 Test Result

PASS

Please refer to the following page.

Angle:		Positive pulses at 90° phase, Negative pulses at 270° phase				
Inject Line	Polarity	Voltage (kV)	Time Interval (Second)	Inject Method	Performance Criterion	Result (Performance Criterion)
L-N	±	1	60	Direct	<input type="checkbox"/> A <input checked="" type="checkbox"/> B	A
L-PE	±	2	60	Direct	<input type="checkbox"/> A <input checked="" type="checkbox"/> B	A
N-PE	±	2	60	Direct	<input type="checkbox"/> A <input checked="" type="checkbox"/> B	A

11. INJECTED CURRENTS SUSCEPTIBILITY TEST

11.1 Test Specification

Test Port	:	input a.c. power port
Step Size	:	1%
Modulation	:	1kHz, 80% AM
Dwell Time	:	1 second

11.2 Test Levels and Performance Criterion

Test Standard
 EN IEC 61000-6-1:2019
 (EN IEC6 1000-4-6:2023)

Frequency ranges MHz	Test level V	Modulation	Performance criterion
0,15 to 80	3	80% AM (1kHz)	A

Performance criterion: **A**

11.3 Test setup

CDN Method

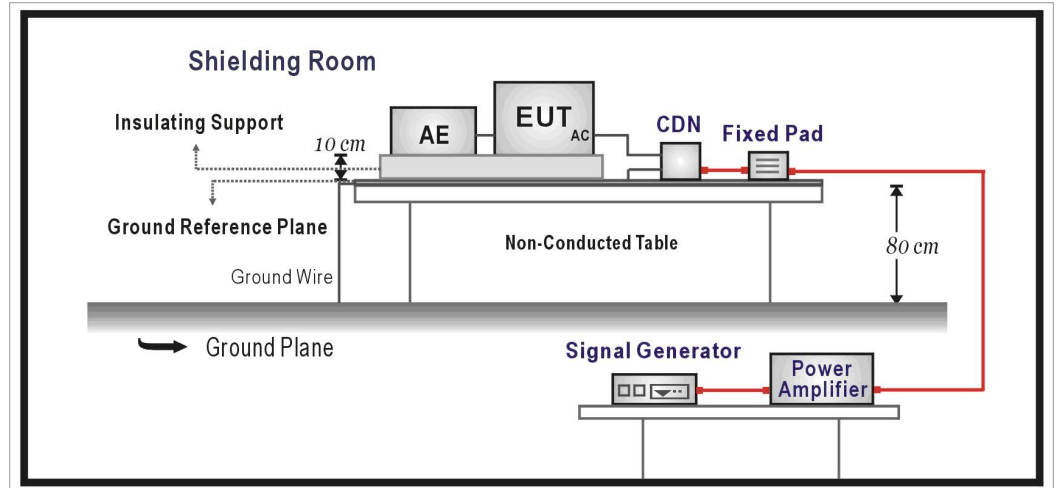

EM Clamp Method

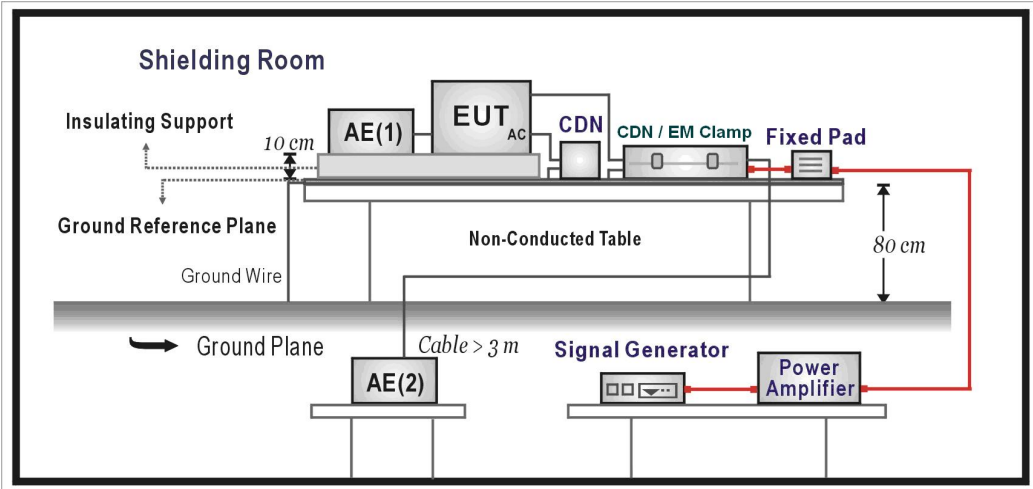

11.4 Test Procedure

- 1) Set up the EUT, CDN and test generator as shown on section 11.1
- 2) Let EUT work in test mode and measure.
- 3) The EUT and supporting equipment are placed on an insulating support 0.1m high above a ground reference plane. CDN (coupling and decoupling device) is placed on the ground plane at above 0.1-0.3m from EUT. Cables between CDN and EUT are as short as possible, and their height above the ground reference plane shall be between 30 and 50 mm (where possible).
- 4) The disturbance signal described below is injected to EUT through CDN.
- 5) The EUT operates within its operational mode(s) under intended climatic conditions after power on.
- 6) The frequency range is swept from 150kHz to 80MHz using 3V signal level, and with the disturbance signal 80% amplitude modulated with a 1kHz sine wave
- 7) The rate of sweep shall not exceed 1.5×10^{-3} decades/s. Where the frequency is swept incrementally, the step size shall not exceed 1% of the start and thereafter 1% of the preceding frequency value.
- 8) Recording the EUT operating situation during compliance test and decide the EUT immunity criterion for above each test.

11.5 Test Result

PASS

Frequency Band (MHz)	Field Strength (Vrms)	Inject Port	Inject Method	Performance Criterion	Result (Performance Criterion)
0.15 ~ 80	3	AC Mains	CDN	<input checked="" type="checkbox"/> A <input type="checkbox"/> B	A

Note 1: The testing performed is from lowest level up to the highest level as required by standard, but only highest level is shown on the report.

Criterion A: Operate as intended during and after the test

Criterion B: Operate as intended after the test

Criterion C: Loss/Error of function

Note 2: The display quality of a display output was evaluated by using a subjective by direct observation.

12. MAGNETIC FIELD IMMUNITY TEST

12.1 Test Levels and Performance Criterion

Test Standard
EN IEC 61000-6-1:2019
(EN 61000-4-8:2010)

Characteristics	Test levels
Field frequency	50/60 Hz
Test level	1 A/m

Performance criterion: **A**

12.2 Test setup

For table-top equipment

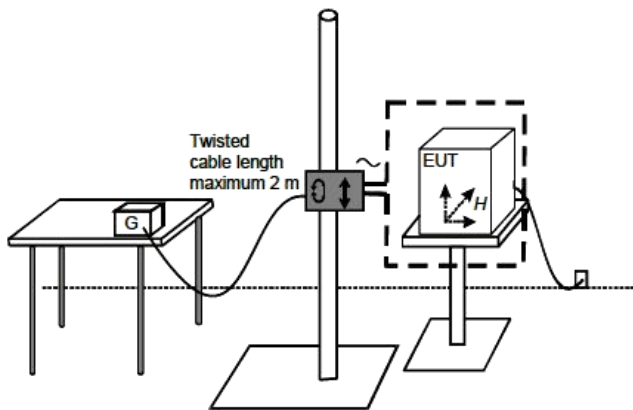

For floor standing equipment

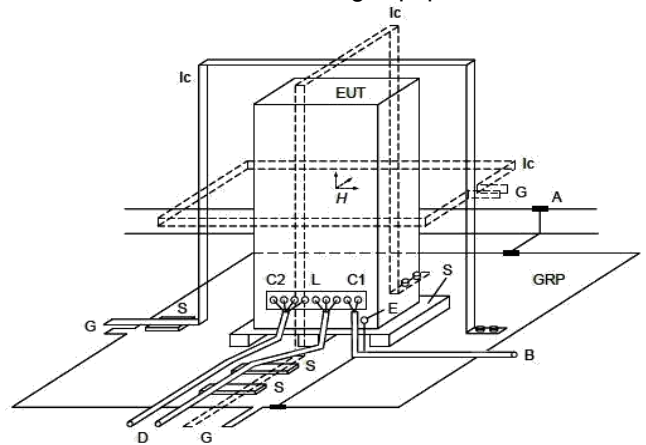

12.3 Test Procedure

The EUT shall be subjected to the test magnetic field by using the induction coil of standard dimensions (1m*1m) and shown in Section 10.1. The induction coil shall then be rotated by 90° in order to expose the EUT to the test field with different orientations.

12.4 Test Results

N/A

The product is not a magnetically sensitive device.

13. VOLTAGE DIPS AND INTERRUPTIONS TEST

13.1 Test Specification

Test Port	:	input a.c. power port
Phase Angle	:	0°, 180°
Test cycle	:	3 times

13.2 Test Levels and Performance Criterion

EN IEC 61000-6-1:2019
(EN IEC 61000-4-11: 2020)

Test Level %UT	Voltage dip and short interruptions %UT	Duration (in period)	
		50Hz	60Hz
0	100	0.5	0.5
0	100	1	1
70	30	25	30
0	100	250	300

Performance criterion: **B, C**

13.3 Test setup

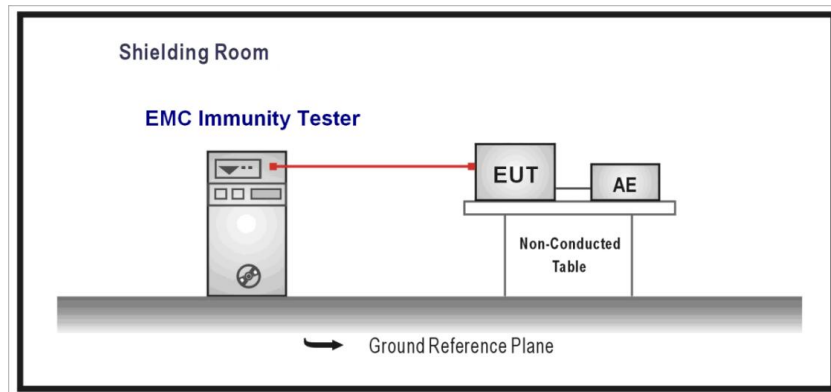

13.4 Test Procedure

- 1) Set up the EUT and test generator as shown on section 12.1.
- 2) The interruption is introduced at selected phase angles with specified duration. There is a 3mins minimum interval between each test event.
- 3) After each test a full functional check is performed before the next test.
- 4) Repeat procedures 2 & 3 for voltage dips, only the level and duration is changed.
- 5) Record any degradation of performance.



13.5 Test Result

PASS

Test Voltage (Vac)	Voltage Residual (%)	Test Duration (Periods)	Performance Criterion	Result (Performance Criterion)
230	0	0.5	<input type="checkbox"/> A <input type="checkbox"/> B <input checked="" type="checkbox"/> C	A
	40	10	<input type="checkbox"/> A <input type="checkbox"/> B <input checked="" type="checkbox"/> C	B
	70	25	<input type="checkbox"/> A <input type="checkbox"/> B <input checked="" type="checkbox"/> C	B

Note 1: The testing performed is from lowest level up to the highest level as required by standard, but only highest level is shown on the report.

Criterion A: Operate as intended during and after the test

Criterion B: Operate as intended after the test

Criterion C: Loss/Error of function

Note2: The power is temporary off and can be reset by the operator.

Attachment 1: Photos of test samples

EUT Photo 1



EUT Photo 2





WUXIANG EUT Photo 3

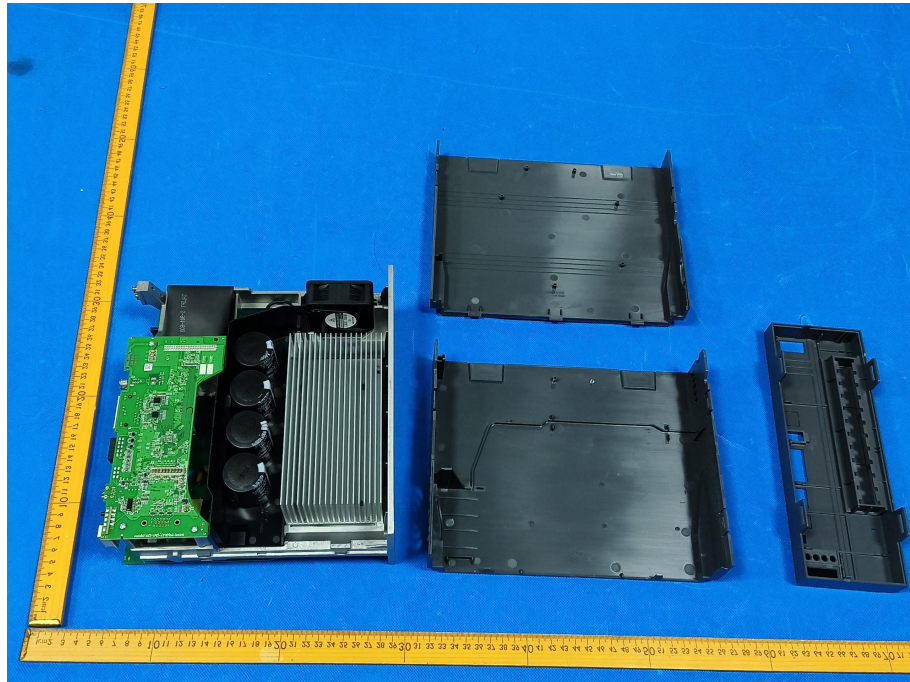

EUT Photo 4





EUT Photo 6

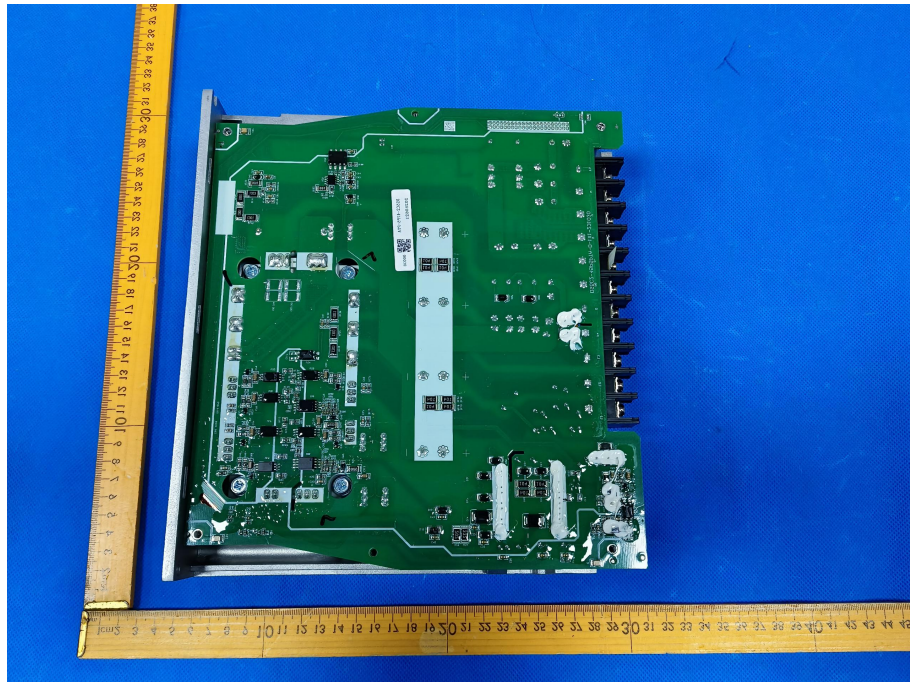



EUT Photo 8

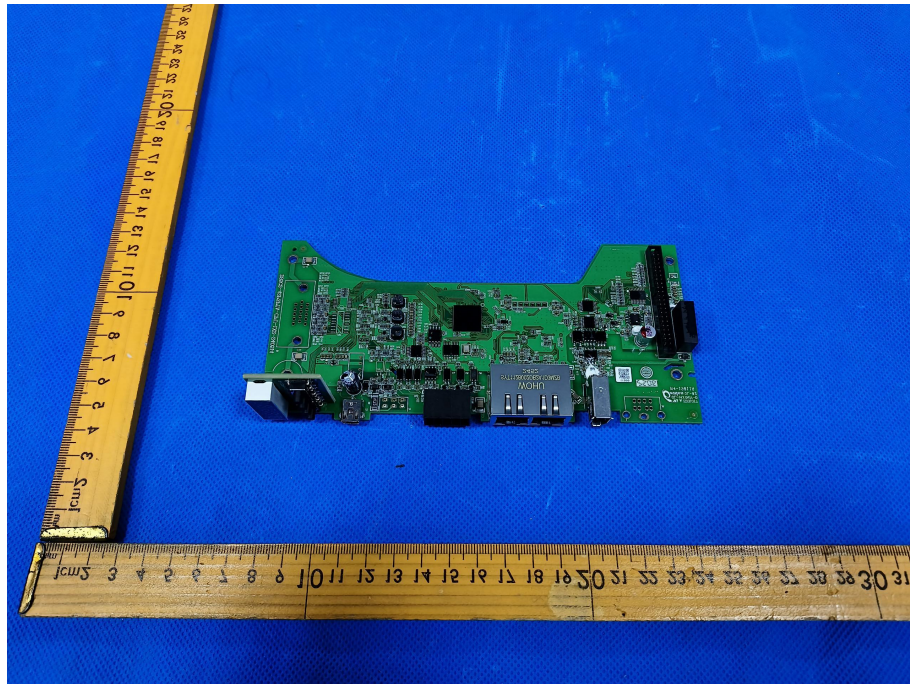

END OF REPORT